

ITEM NO	QTY	DESCRIPTION
1	2	DESICCANT VESSEL
2	2	INLET BUTTERFLY VALVE
3	2	PURGE EXHAUST BUTTERFLY VALVE
4	1	PURGE EXHAUST MUFFLER
5	2	OUTLET CHECK VALVE
6	2	HEATER OUTLET CHECK VALVE
7	2	VESSEL PRESSURE GAUGE
8	2	PRESSURE RELIEF VALVE
9	1	HEATER
10	1	PURGE ADJUSTMENT VALVE
11	1	PURGE PRESSURE GAUGE
12	1	ELECTRICAL ENCLOSURE
13	1	PRE-FILTER
14	1	AFTER FILTER
15	1	ZERO-LOSS DRAIN

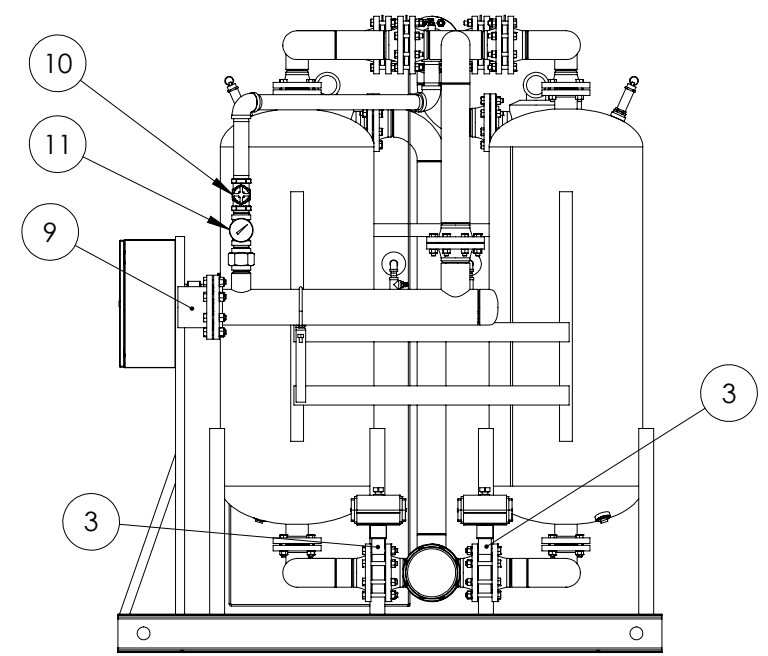
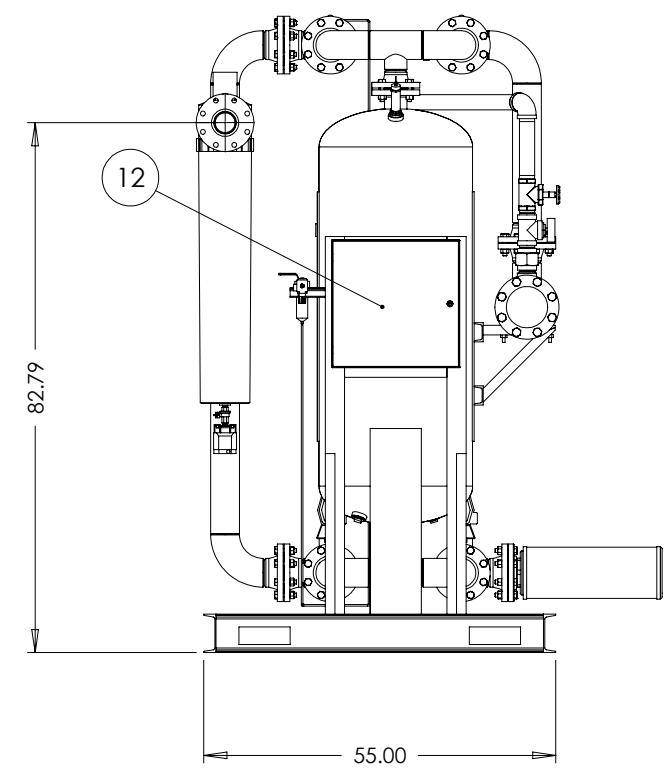
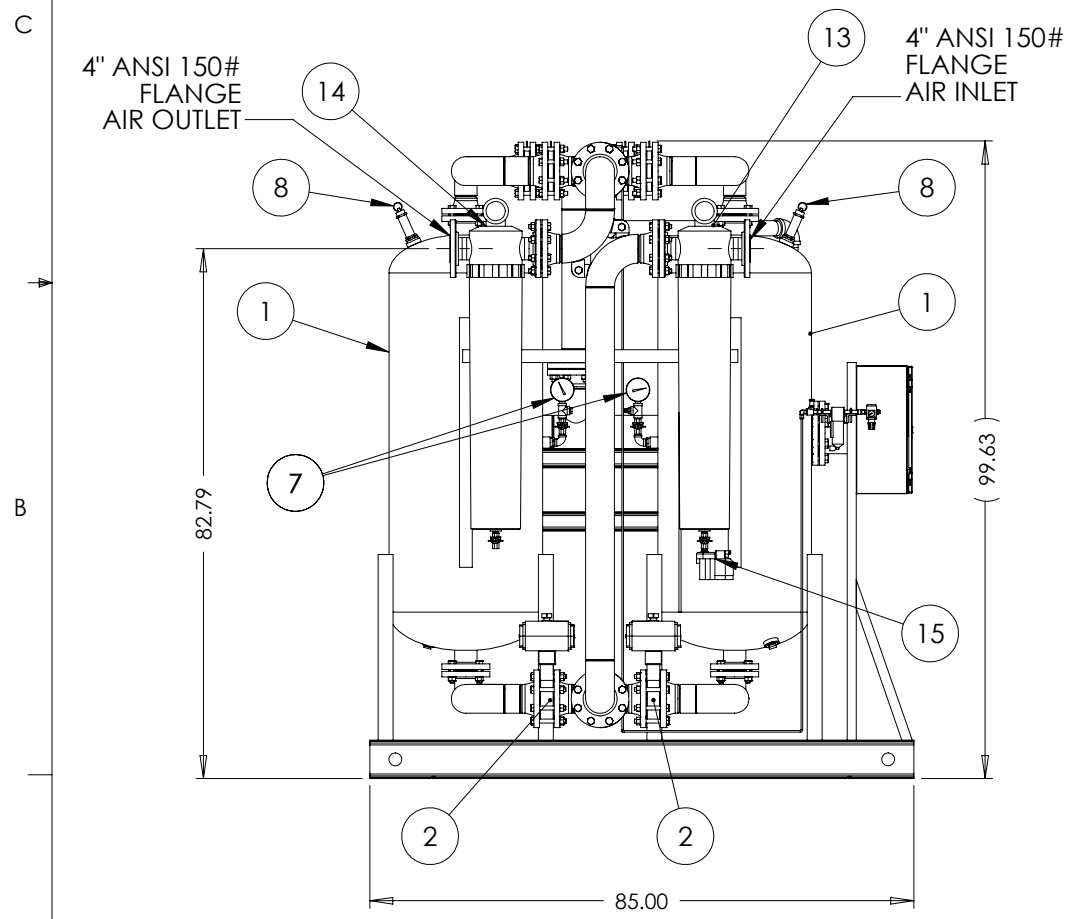

**PROPRIETARY AND CONFIDENTIAL**  
 THE INFORMATION CONTAINED IN THIS DRAWING IS THE SOLE PROPERTY OF AIRCEL LLC. ANY REPRODUCTION IN PART OR AS A WHOLE WITHOUT THE WRITTEN PERMISSION OF AIRCEL LLC IS PROHIBITED.

UNLESS OTHERWISE SPECIFIED:  
 DIMENSIONS ARE IN INCHES  
 TOLERANCES:  
 FRACTIONAL: ± 0.125  
 ANGULAR: ± 0.5°  
 TWO PLACE DECIMAL ± .03  
 THREE PLACE DECIMAL ± .003

THIRD ANGLE PROJECTION  
 MATERIAL  
 FINISH  
 DO NOT SCALE DRAWING

	NAME	DATE
DRAWN	O.P.	10/11/13
CHECKED		
ENG APPR.		
MFG APPR.		
Q.A.		
COMMENTS:		

**Aircel** COMPRESSED AIR AND GAS PRODUCTS  
 323 CRISP CIRCLE  
 MARYVILLE TENNESSEE 37801  
 PHONE: 865-681-7066  
 FAX: 865-681-7069

**TITLE:** DRYER, DESICC., AEHD-1600, PACK B, 1 PRE & 1 AFTER FILTER, 150 PSIG, 100 DEG F, T-24, REV 1

<b>SIZE</b> <b>B</b>	<b>DWG. NO.</b> AG9904340-B	<b>REV</b> <b>1</b>
<b>SCALE:</b> 1:50		<b>WEIGHT:</b>
		<b>SHEET 1 OF 1</b>