

ITEM NO	QTY	DESCRIPTION
1	2	DESICCANT VESSEL
2	1	INLET SHUTTLE VALVE
3	1	OUTLET SHUTTLE VALVE
4	2	PURGE EXHAUST VALVE
5	2	EXHAUST MUFFLER
6	2	PRESSURE GAUGE
7	2	PRESSURE RELIEF VALVE
8	1	ELECTRICAL ENCLOSURE
9	1	CARBON MONOXIDE MONITOR
10	1	PRE-FILTER
11	1	ACTIVATED CARBON FILTER
12	1	AFTER FILTER
13	1	ZERO-LOSS DRAIN

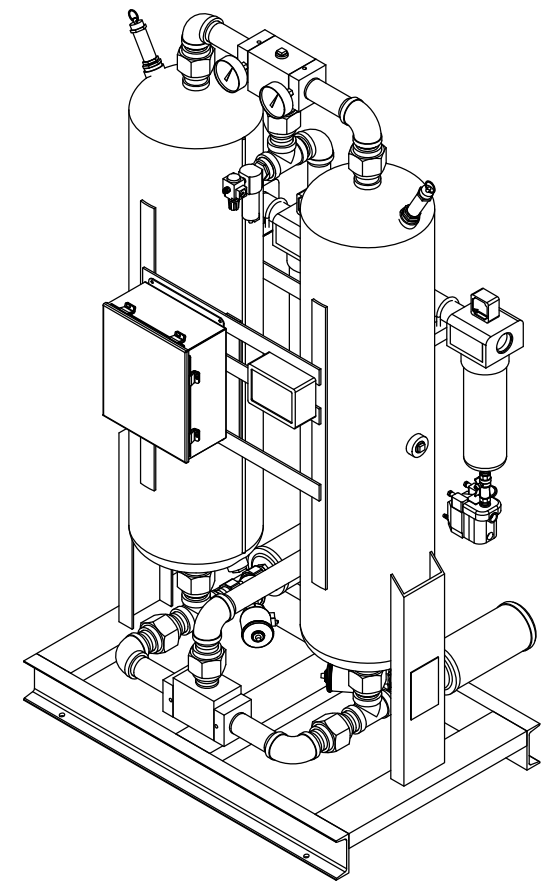

UNLESS OTHERWISE SPECIFIED:
 DIMENSIONS ARE IN INCHES
 TOLERANCES:
 FRACTIONAL ± 0.125
 ANGULAR: ± 0.5°
 TWO PLACE DECIMAL ± .03
 THREE PLACE DECIMAL ± .003

THIRD ANGLE PROJECTION

MATERIAL

FINISH

DO NOT SCALE DRAWING

	NAME	DATE
DRAWN	O.P.	02/21/12
CHECKED	M.S.	02/21/12
ENG APPR.		
MFG APPR.		
Q.A.		
COMMENTS:		

		<small>COMPRESSED AIR AND GAS PRODUCTS 323 CRISP CIRCLE MARYVILLE TENNESSEE 37801 PHONE: 865-681-7066 FAX: 865-681-7069</small>	
		TITLE: DRYER, DESICC, BHD-350 STD ASSY: 1 PRE & 2 AFTER FILTERS; 200 PSIG, 100 F, T-14, REV 2	
SIZE B	DWG. NO. AG9978040		
SCALE: 1:50	WEIGHT:	SHEET 1 OF 1	

PROPRIETARY AND CONFIDENTIAL
 THE INFORMATION CONTAINED IN THIS DRAWING IS THE SOLE PROPERTY OF AIRCEL LLC. ANY REPRODUCTION IN PART OR AS A WHOLE WITHOUT THE WRITTEN PERMISSION OF AIRCEL LLC IS PROHIBITED.