

ITEM NO	QTY	DESCRIPTION
1	2	DESICCANT VESSEL
2	1	INLET SHUTTLE VALVE
3	1	OUTLET SHUTTLE VALVE
4	2	PURGE EXHAUST VALVE
5	2	EXHAUST MUFFLER
6	2	PRESSURE GAUGE
7	2	PRESSURE RELIEF VALVE
8	1	ELECTRICAL ENCLOSURE
9	1	CARBON MONOXIDE MONITOR
10	1	PRE-FILTER
11	1	ACTIVATED CARBON FILTER
12	1	AFTER FILTER - FINAL PARTICULATE
13	1	ZERO-LOSS DRAIN

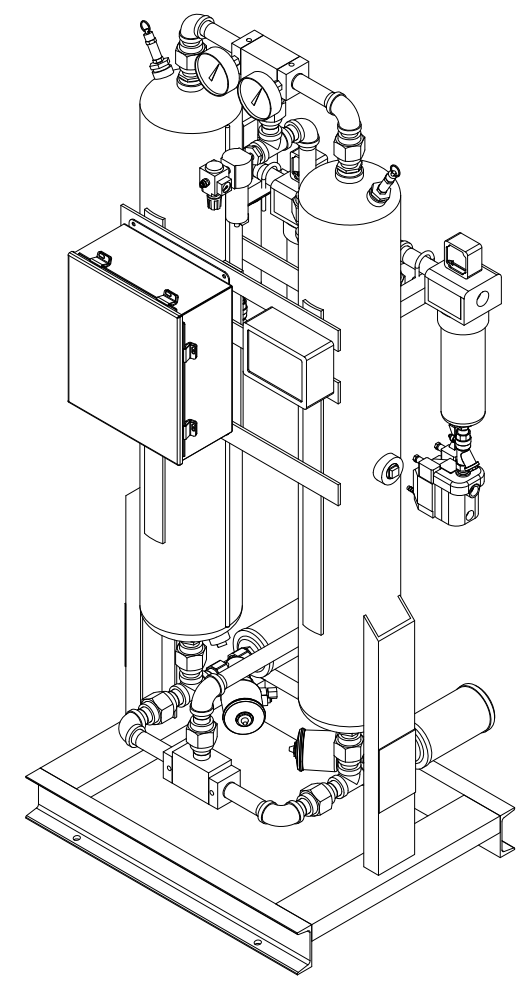

UNLESS OTHERWISE SPECIFIED:
 DIMENSIONS ARE IN INCHES
 TOLERANCES:
 FRACTIONAL ± 0.125
 ANGULAR: ±0.5°
 TWO PLACE DECIMAL ± .03
 THREE PLACE DECIMAL ± .003

THIRD ANGLE PROJECTION
 MATERIAL
 FINISH
 DO NOT SCALE DRAWING

	NAME	DATE
DRAWN	O.P.	02/08/12
CHECKED	M.S.	02/08/12
ENG APPR.		
MFG APPR.		
Q.A.		
COMMENTS:		

Aircel COMPRESSED AIR AND GAS PRODUCTS
 323 CRISP CIRCLE
 MARYVILLE TENNESSEE 37801
 PHONE: 865-681-7066
 FAX: 865-681-7069

TITLE: DRYER, DESICC, BHD-100
 STD ASSY: 1 PRE & 2
 AFTER FILTERS; 200 PSIG,
 100 DEG F, T-8, REV 2

SIZE DWG. NO.
B AG9977540

SCALE: 1:20 WEIGHT: SHEET 1 OF 1

PROPRIETARY AND CONFIDENTIAL
 THE INFORMATION CONTAINED IN THIS DRAWING IS THE SOLE PROPERTY OF
 AIRCEL LLC. ANY REPRODUCTION IN PART OR AS A WHOLE WITHOUT THE
 WRITTEN PERMISSION OF AIRCEL LLC IS PROHIBITED.