



Wire Mesh Separator,
Coiled Construction
with Supporting Grid

DW Separator Features

- Carbon steel construction (stainless steel as an option).
- 304 SS demister pad.
- Large connections - FLG on 3" and above.
- Zero-air loss float type condensate drain included.
- "U" stamped ASME rated vessels.
- Reduced power and energy consumption.
- Horizontal and vertical designs available.
- Floor mount frames provided with larger models.
- Higher operating pressure available on request.

DW Separator Benefits

- Low pressure drop resulting in energy savings.
- High bulk liquid and fine mist removal efficiency (Typically >99%).
- Highly efficient moisture separation.
- Effective airflow range from 10-150% of design velocity.
- Extended life expectancy.
- Multiple material constructions.

The Aircel DW Demisting Wire Mesh Moisture Separator provides high efficiency separation of both bulk and fine mist aerosol liquids with very low pressure loss, typically greater than 99.9% removal efficiency for water mist aerosols 10 microns and larger, and less than 1.0 In. water column differential pressure.

The pressure loss is lower and the removal efficiency higher than provided by other impingement separation devices such as centrifugal and cyclone separators, baffled liquid knock-out pots, and even wet receivers. The DW series provides separation of both bulk and aerosol liquids at a fraction of the pressure loss consumed by fibrous coalescing mist eliminators.

The Demisting Wire Mesh Moisture Separator is a knitted and crimped impingement separator designed to remove liquid aerosols by four primary methods: 1. Impaction on the wires, 2. liquid adhesion to the wire media, 3. agglomeration of the aerosol droplets, and 4. disengagement of the droplets. The design velocity of the compressed air through the wire mesh separator is sufficient to assure high separation efficiency without allowing entrainment of the coalesced droplets into the upward flowing airstream. The coalesced droplets descend into the sump of the vessel by gravity and an automatic drain valve removes the liquid continuously.

Sustainable Energy Savings

Low Pressure Drop Results in Reduced Energy Consumption

DW SERIES Compressed Air & Process Filtration

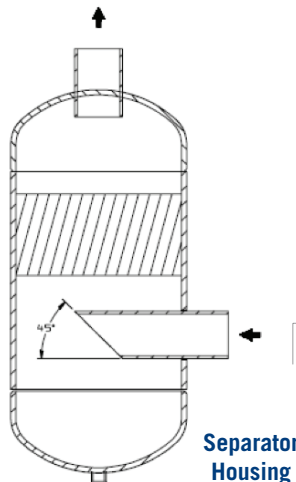

Wire mesh separators have a much larger velocity range than other separation devices due to the multitude of wires offering impact surfaces between the inlet and the outlet of the wire mesh pad. The operating range is from about 10% of the design velocity to about 150%.

Showing Chamfered Inlet Pipe, Sump, and Space Above and Below Wire Mesh Pad to Provide Disengagement Height and Uniform Flow Distribution.

DW SERIES TECHNICAL SPECIFICATIONS



DW SERIES Model Comparison

Model Number	DW-6	DW-10	DW-25	DW-45	DW-65	DW-100	DW-150	DW-250	DW-720	DW-1200	DW-1600	DW-2000	DW-2500	DW-3000	DW-4000	DW-6000
Shell Diameter Nominal	3/4"	1"	1½"	2"	2 ½"	3"	4"	5"	8"	10"	12"	14"	16"	18"	20"	24"
Flow Rate* (scfm)	6	10	25	45	65	100	150	250	720	1200	1600	2000	2500	3000	4000	6000
Connection (inch)	¼"	¼"	½"	½"	¾"	1"	1"	1½"	2"	2½"	3"	4"	4"	4"	6"	6"
Connection Type	NPT	NPT	MPT	MPT	MPT	MPT	MPT	MPT	MPT	MPT	150lb FLG	150lb FLG	150lb FLG	150lb FLG	150lb FLG	150lb FLG
Height (in)	18	20	24	26	28	30	32	34	36	38	40	42	44	48	52	54
Width (in)	8	8	8	8	8	10	10	12	14	16	18	20	22	24	26	28
Depth (in)	4	4	6	6	8	8	10	12	12	14	16	18	20	22	24	26
Weight (lbs)	5	10	15	20	30	40	50	60	100	160	220	280	320	360	400	440

* Flow Rates calculated at 100 psig and 100°F.

All standard separator housings are carbon steel: SA106B for DW-6 to DW-250, SA53B for larger housings. Model DW-720 and larger, shells are "U" stamped per ASME Section VIII Division 1 for 200 psig and 450°F. Drain valve is rated for 150 psig at 150°F and has a capacity of 2.25 gpm at 150 psig. Model DW-720 and larger separators are provided with a floor mount frame. Due to a continuous program of product improvement, specification and dimensions are subject to change without notice.

DW SERIES Demisting Wire Mesh Moisture Separator

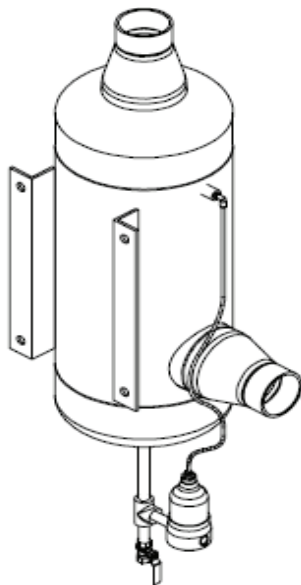

**Continuous Float Operated Zero
Air-Loss Drain Valve**

The wire mesh separator is composed of 304 stainless steel wires. The wires are looped at each intersection throughout the wire mesh pad. As the liquid mist droplets collect on the wires, larger droplets form which accumulate at the looped intersections. When the droplets are sufficiently enlarged, they separate from the wire mesh and fall by gravity to the sump, countercurrent to the direction of the air flow through the pad. Support grids of stainless steel rod or grating are provided to prevent the pad from bowing.

Wire mesh separators have a much larger velocity range than other separation devices due to the multitude of wires offering impact surfaces between the inlet and the outlet of the wire mesh pad. The operating range is from about 10% of the design velocity to about 150%.

Demisting wire mesh separators can achieve virtually 100% mist separation for water aerosols 5 to 10 micron in diameter and larger. Oil aerosols with low surface tension and low cohesive attraction are stable in the submicron size range, and to separate oil mist, coalescing filters are required.

The Demisting separator housing is fitted with large inlet and outlet ports to minimize the entry and exit pressure losses. The inlet pipe is brought into the vessel about midway and is cut at a 45° angle to reduce the jetting effect of the fluid striking the opposite vessel wall. A float operated drain valve is connected to the sump to continuously remove the condensate.