

REFRIGERATED NON-CYCLING

COMPRESSED AIR DRYERS

VF SERIES

MODEL VF-100

100 SCFM REFRIGERATED NON-CYCLING AIR DRYER

Aircel's VF line of refrigerated dryers are focused on reliable, constant dewpoint performance in all flow conditions. With its excellent heat transfer coefficients and low pressure drop, these dryers will outperform the competition in protecting your compressed air system, machinery and tools; and will improve your manufacturing processes.

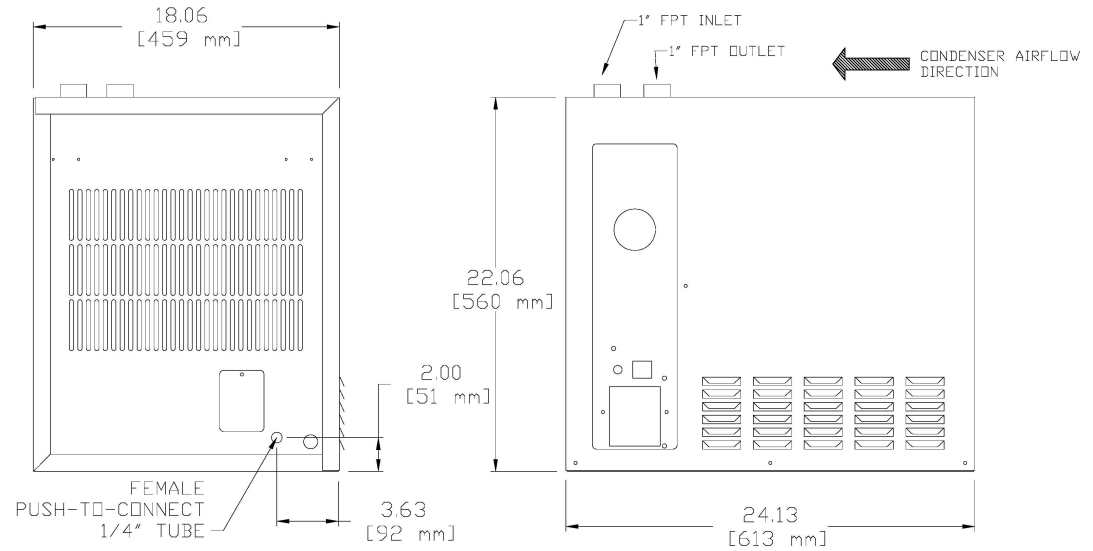

MODEL VF-100 DIMENSIONS

STANDARD FEATURES

- ◇ Patented High Efficiency four Stage Aluminum Block Heat Exchanger
- ◇ Integrated Regenerating Heat Exchanger Prevents "Sweating" of Pipes
- ◇ Moisture Separator Integrated into Heat Exchanger
- ◇ Hot Gas Bypass Valve for Low-Load Condition
- ◇ Heavy Duty Industrial Powder Coated Steel Cabinet with Access Panel
- ◇ Refrigerant Suction Gauge
- ◇ Environmentally Friendly R-134a Refrigerant
- ◇ Refrigerant Liquid Line Filter

AVAILABLE OPTIONS

- ◇ Water Cooled Condenser
- ◇ Corrosive Environment Protection
- ◇ Elevated NEMA Ratings Through NEMA 7 Class I, Division I
- ◇ Pre-Sized Filter Package
- ◇ Dryer Bypass System
- ◇ Additional Gauges: Air Temperature, Air Pressure, Refrigerant Discharge
- ◇ Stainless Steel Piping
- ◇ Alternate Voltages

Contact an Aircel representative for assistance with custom requirements.

MECHANICAL SPECS

Flow Capacity, 38°F Dew-point	100 SCFM
Inlet Air Pressure, Design / Max	100 / 200 PSIG
Inlet Air Temperature, Design / Max ¹	100 / 140 °F
Ambient Air Temperature, Design / Max / Min ¹	100 / 120 / 40 °F
Pressure Loss, Design	4.2 PSI
Condenser Type	Air Cooled
Cooling Air Flow	300 CFM
Heat Rejection	7.4 kBTU/hr
Air Connections	1" FPT
Condensate Connection	1/4" Tube
Unit Weight	132 LBS

ELECTRICAL SPECS

Power Connection	115-1-60
Full Load Power	0.90 kW
Rated Load	10.7 A
NEMA Rating	1



AIRCEL LLC
323 CRISP CIRCLE
MARYVILLE, TENNESSEE
37801

PHONE
(800) 767-4599
LOCAL: (865) 681-7066
FAX: (865) 681-7069

SALES INFORMATION
sales@airceldryers.com
REQUEST LITERATURE:
litrequest@airceldryers.com

¹ Unit performance may be reduced at elevated inlet and/or ambient temperatures.