

**REFRIGERATED NON-CYCLING**

**COMPRESSED AIR DRYERS**

**DHT SERIES**

**MODEL DHT-125**

**125 SCFM HIGH-TEMP REFRIGERATED NON-CYCLING AIR DRYER**

Aircel's DHT line of high-temperature refrigerated dryers are focused on reliable, constant dewpoint performance in all flow conditions. With its excellent heat transfer coefficients and low pressure drop, these dryers will outperform the competition in protecting your compressed air system, machinery and tools; and will improve your manufacturing processes.

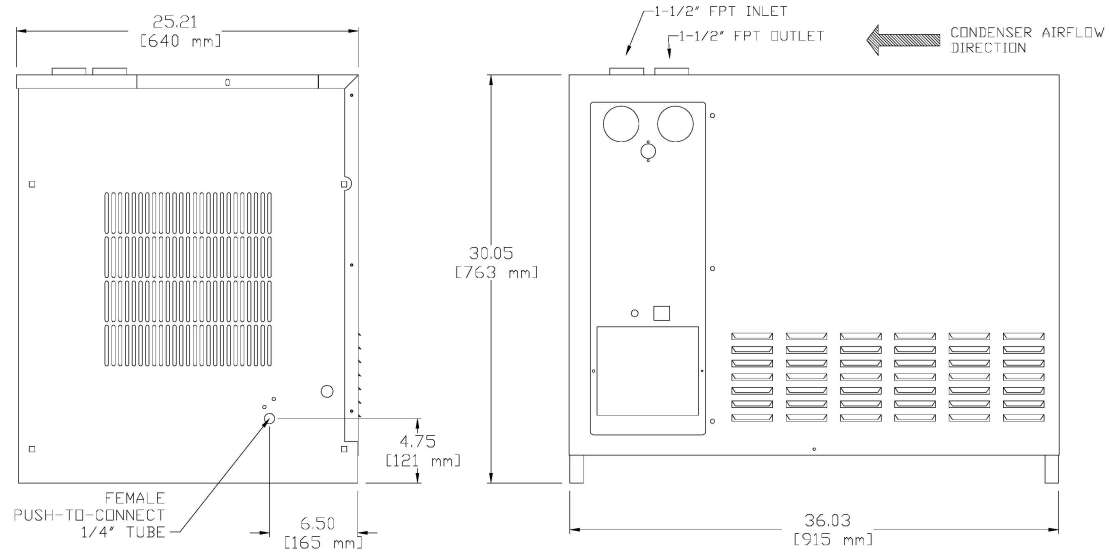

MODEL DHT-125 DIMENSIONS

**STANDARD FEATURES**

- ◇ Patented High Efficiency four Stage Aluminum Block Heat Exchanger
- ◇ Integrated Regenerating Heat Exchanger Prevents "Sweating" of Pipes
- ◇ Moisture Separator Integrated into Heat Exchanger
- ◇ Hot Gas Bypass Valve for Low-Load Condition
- ◇ Heavy Duty Industrial Powder Coated Steel Cabinet with Access Panel
- ◇ Refrigerant Suction and Discharge Gauges
- ◇ Environmentally Friendly R-134a Refrigerant
- ◇ Refrigerant Liquid Line Filter
- ◇ Automatic Adjustable Timer Drain

**AVAILABLE OPTIONS**

- ◇ Water Cooled Condenser
- ◇ Corrosive Environment Protection
- ◇ Elevated NEMA Ratings Through NEMA 7 Class I, Division I
- ◇ Pre-Sized Filter Package
- ◇ Dryer Bypass System
- ◇ Additional Gauges: Air Temperature, Air Pressure
- ◇ Stainless Steel Piping
- ◇ Alternate Voltages

Contact an Aircel representative for assistance with custom requirements.

**MECHANICAL SPECS**

|   |                   |
|---|-------------------|
| Flow Capacity, 38°F Dew-point                           | 125 SCFM          |
| Inlet Air Pressure, Design / Max                        | 175 / 200 PSIG    |
| Inlet Air Temperature, Design / Max <sup>1</sup>        | 180 / 205 °F      |
| Ambient Air Temperature, Design / Max /Min <sup>1</sup> | 100 / 120 / 40 °F |
| Pressure Loss, Design                                   | 0.8 PSI           |
| Condenser Type  | Air Cooled        |
| Cooling Air Flow  | 710 CFM           |
| Heat Rejection  | 12.1 kBTU/hr      |
| Air Connections   | 1.5" FPT          |
| Condensate Connection                                   | 1/4" Tube         |
| Unit Weight   | 310 LBS           |

**ELECTRICAL SPECS**

|                  |          |
|------------------|----------|
| Power Connection | 230-1-60 |
| Full Load Power  | 2 kW     |
| Rated Load       | 7.47 A   |
| NEMA Rating      | 1        |



AIRCEL LLC  
323 CRISP CIRCLE  
MARYVILLE, TENNESSEE  
37801

PHONE  
(800) 767-4599  
LOCAL: (865) 681-7066  
FAX: (865) 681-7069

SALES INFORMATION  
sales@airceldryers.com  
REQUEST LITERATURE:  
litrequest@airceldryers.com

<sup>1</sup> Unit performance may be reduced at elevated inlet and/or ambient temperatures.