



OFP-100

## Oilfreepac Benefits

- Pure, Oil-free compressed air
- Easy installation and setup
- Perfect for treatment of partial flows
- For use with oil-free or oil-flooded compressor systems
- Less maintenance and downtime due to repairs
- Increased cost savings

The **Aircel Oilfreepac Purification System (50 - 5,000 scfm)** removes water, oil and dirt particles from your compressed air in one process for clean, oil-free and odor-free air. It is an efficient and reliable heatless compressed air purifier providing an outlet dewpoint of either -40°F or -100 °F (Optional). The Oilfreepac system filters oil and adsorbs oil vapor so thoroughly that the residual oil content is below normal detection limits, 1000 times more pure than the normal atmospheric air that we breathe.

Instead of ill-matching individual units the Oilfreepac is a **compact system solution**, complete with a desiccant air dryer, hydrocarbon removal, hydrocarbon monitor, automatic shut off and electronic controls. When the hydrocarbon monitor detects excessive levels of oil vapor, the controls close the automatic outlet valve, put the dryer in standby and protect the equipment downstream.

The Oilfreepac not only guarantees you oil free compressed air satisfying the highest standards, it also provides maximum operational reliability with either Oil-Free or Oil-Lubricated compressors. Oil-free Compressors with dry rotors are more expensive to buy, more expensive to maintain and because of their energy consumption, more expensive to operate. This is why the Aircel Oilfreepac Systems are the preferred choice to provide the best advantages in performance and economy.

## Oilfreepac Features

- Complete pre-piped system
- Includes prefilter, particulate/carbon filter
- NEMA 12 electronic controls
- Hydrocarbon gas monitor
- Automatic shut off valve to prevent hydrocarbon breakthrough

## OILFREEPAC SERIES

### How it Works

Compress air enters the system (A) through a Submicron coalescing filter (1) that removes the particles and the condensate mist to less than 0.01 ppm. The condensate is removed by a zero air-loss drain valve (2) and exits the system (B). The air enters the heatless adsorber through the lower Automatic Piston Valve (APV) (3). The air passes through the inlet air diffuser (4) into the adsorbent bed (5) where the moisture and hydrocarbon vapors are removed.

The compressed air then passes through the outlet flow diffuser (6) and APV (7) into the final filter (8) where residual oil vapors and adsorbent fines are removed. The clean and oilfree air leaves the purifier and enters the distribution system (C) through the outlet valve (9).

The outlet air quality is continuously monitored with a hydrocarbon detector (10) and in the event that excessive levels of oil vapor are detected, the outlet valve is automatically closed and the system alarm is activated.

While one adsorbent vessel is purifying the compressed air, the other vessel is taken off line and regenerated. A partial stream of purified air is expanded to atmospheric pressure through an orifice (11) and passed through the regenerating vessel. The purging air and contaminants are exhausted to atmosphere (D) through an exhaust valve (12) and muffler (13).

When the first adsorbent vessel becomes contaminated, the regenerated vessel is put on-line and the contaminated vessel is taken off line for regeneration. The process is continuous.

### Applications

- Pharmaceutical
- Food and Beverage
- Semi-Conductor

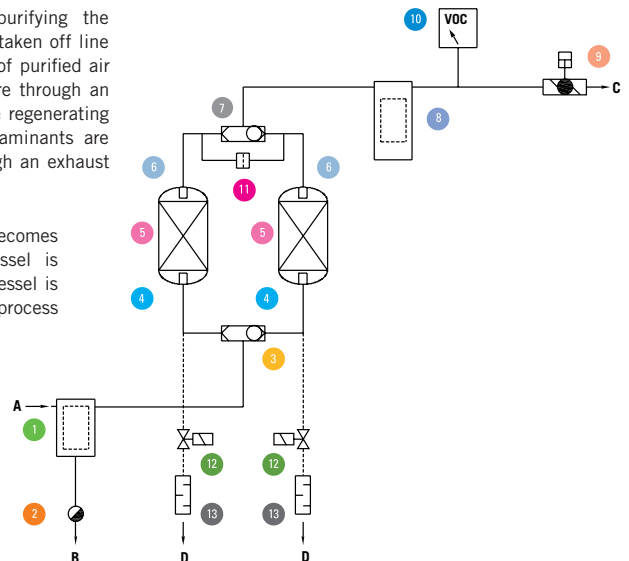

# OILFREEPAC SERIES TECHNICAL SPECIFICATIONS



## Oilfreepac Model Comparison

Model	Capacity <sup>1</sup> (scfm)	Connection (NPT/ANSI)	Dimensions (inches)			Standard Voltage <sup>2</sup>	Weight (lbs)
			Height	Width	Depth		
OFP-50	50	1/2"	70	41	24	115V/60Hz	400
OFP-80	80	3/4"	77	41	25	115V/60Hz	420
OFP-100	100	1"	77	41	25	115V/60Hz	575
OFP-125	125	1"	77	41	25	115V/60Hz	600
OFP-150	150	1"	85	41	25	115V/60Hz	625
OFP-200	200	1 1/2"	86	42	25	115V/60Hz	888
OFP-300	300	1 1/2"	87	50	32	115V/60Hz	1075
OFP-450	450	2"	91	56	32	115V/60Hz	1240
OFP-500	500	2"	91	56	32	115V/60Hz	1290
OFP-600	600	2"	91	56	32	115V/60Hz	2040
OFP-750	750	3" FLG	93	70	42	115V/60Hz	2760
OFP-1000	1000	3" FLG	98	74	42	115V/60Hz	3960
OFP-1250	1250	3" FLG	98	74	42	115V/60Hz	4150
OFP-1500	1500	4" FLG	109	98	54	115V/60Hz	5580
OFP-2000	2000	4" FLG	109	98	54	115V/60Hz	6080
OFP-2500	2500	4" FLG	115	118	64	115V/60Hz	6880
OFP-3000	3000	6" FLG	120	128	74	115V/60Hz	8250
OFP-3500	3500	6" FLG	125	128	74	115V/60Hz	8850
OFP-4000	4000	6" FLG	128	128	85	115V/60Hz	9750
OFP-5000	5000	6" FLG	136	136	90	115V/60Hz	12500

## Oilfreepac Optional Features

- NEMA 4, 7 or any other NEMA is optional
- Failure to shift alarm.
- High inlet temperature alarm.
- Dew point monitor.
- Demand cycle control with dew point monitor.
- Visual moisture indicator.
- High inlet pressure.
- Purge flow meter.

1. Capacity rated in accordance with CAGI ADF 200 Capacity based on -40°F dpd, 100 psig inlet pressure, 100°F inlet temperature and 100°F ambient. Minimum operating pressure: 60 psig, Maximum operating pressure: 150 psig.

2. Standard power supply: 115V/60Hz, for other options, consult Aircel Representative.

Due to a continuous program of product improvement, specification and dimensions are subject to change without notice.

## Oilfreepac Series Capacity Correction Factors

### To Size the Dryer Capacity for Actual Conditions

$$\text{Adjusted Capacity} = \text{scfm} \times C1 \times C2$$

To calculate the capacity of a given dryer based on non-standard operating conditions, multiply the standard capacity by the appropriate correction factor(s).

**EXAMPLE:** Dryer Model: OFP-500  
Standard Capacity: 500 scfm  
Actual Operating Conditions: 140 psig working pressure: C1 = 1.35  
100°F inlet temperature: C2 = 1.0  
Adjusted Capacity = 500 scfm x 1.35 x 1.0 = **675 scfm**

### To Select the Dryer Model for Actual Conditions

$$\text{Adjusted Capacity} = \text{scfm}/C1/C2$$

To choose a dryer based on a given flow at non-standard operating conditions, divide the given flow by the appropriate correction factor(s).

**EXAMPLE:** Given Flow: 750 scfm  
Actual Operating Conditions: 120 psig working pressure: C1 = 1.18  
100°F inlet temperature: C2 = 1.0  
Adjusted Capacity = 750 scfm / 1.18 / 1.0 = **636 scfm**  
Selected Dryer Model: **OFP-750**

The Compressed Air and Gas Institute (CAGI) has developed standards to protect users of compressed air & gas equipment. ADF200 the current standard for desiccant compressed air dryers, specifies the dryers performance to be rated at 100°F inlet temperature, 100°F

ambient temperature, and 100 psig system pressure. To adjust the dryer capacity from these "CAGI conditions" to your specific application, please use the correction factors below for differing inlet air temperatures (C1) and system pressures (C2).

### Capacity correction factors for system air pressure (C1)

System Pressure (psig)	60	70	80	90	100	110	120	130	140	150
Correction Factor	0.65	0.73	0.82	0.91	1	1.09	1.18	1.27	1.35	1.44

### Capacity correction factors for inlet air temperature (C2)

Inlet Temperature (°F)	70	80	90	100	105*	110*	115*	120*
Correction Factor	1.2	1.15	1.10	1	0.9	0.8	0.7	0.6

\*For inlet temperature above 100°F, molecular sieve desiccant is required